

# LB2

## Submittal

Style LB-2  
Slope Top Enclosure  
Copper/Aluminum  
& Steel Ratings

# Specification

### ENCLOSURE:

- STYLE : LB2  
 OUTLET: Slope Louvered  
 Pencil Proof  
 LENGTHS: 2'0" thru 8'0" (Std)  
 in 6" increments  
 MATERIAL:  18 Ga. CRS (Std)  
 16 Ga. CRS Opt'l  
 14 Ga. CRS Opt'l  
 Stainless Steel, Alum.  
 Available Consult Factory  
 FINISH:  Baked Powder (Std)  
 Baked Metallic (Opt'l)

### BACKPLATE:

- TYPE:  Full B/P to Floor  
 Standard used with  
 standard or adjustable rod  
 hangers  
 LENGTHS: 2'0" thru 8'0" in 6" increments  
 MATERIAL:  20 Ga. CRS with  
 Baked Prime Finish  
 Opt'l Baked Powder Color  
 TYPE:  Partial Backplate used  
 with Intermediate Bottom  
 Support Brkt. with Ball  
 Bearings  
 LENGTHS: 8'0" (Std)  
 MATERIAL:  20 Ga. Prepainted (Std)  
 18 Ga. Galvannealed

### ELEMENT:

- TYPE: Cu/Al (Mechanically  
 Expanded)  
 LENGTHS: R01 thru R05, 2'0" thru 8'0"  
 in 12" increments  
 R06 thru R10, 2'0" thru  
 12'6" in 1" increments  
 One End Flared, (Std)  
 TYPE: IPS Steel (Mechanically  
 Expanded)  
 LENGTHS: 2'0" thru 12'0" in 1"  
 increments  
 NPT Thread both Ends (Std)  
 Beveled Ends for Field Weld

- SUPPORTS:  Rod Hanger Std with  
 Full Backplate  
 Adj. Rod hanger Opt'l  
 with Part B/P or Full B/P  
 18 Ga. Galv. Slide  
 Cradle opt'l with Int.  
 Bottom w/Ball Bearings

### ENCLOSURE

- SUPPORTS:  Intermediate Bottom  
 Support  
 Intermediate Bottom  
 Support with Ball Bearings  
 DAMPER: (Opt'l)  
 Knob  
 Tamper Resistant  
 AIR SEAL: (Opt'l)  
 1/8" x 3/8" Closed Cell.  
 ACCESSORIES: All overlapping,  
 engage between  
 backplate and wall at  
 top. Bottom returns to  
 wall, holes provided  
 for fasteners.

### FULL BACKPLATE INSTALLATION

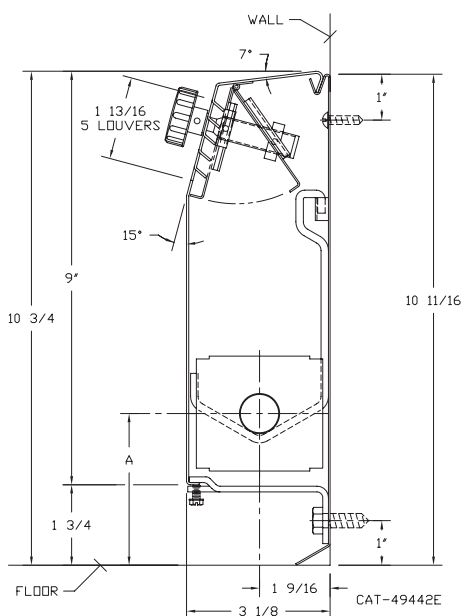

TUBE SIZE	FIN SIZE HEIGHT x WIDTH	A
3/4 COPPER	2 1/2 x 2 3/4	3 3/16
1" COPPER	2 1/2 x 2 3/4	3 5/16

### PARTIAL BACKPLATE INSTALLATION

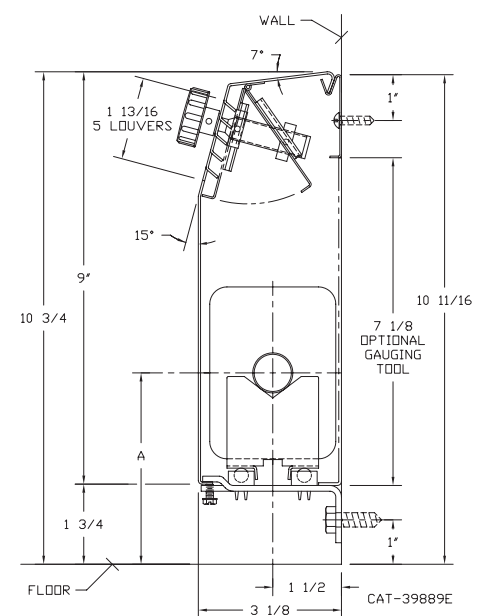

TUBE SIZE	FIN SIZE HEIGHT x WIDTH	CRADLE NUMBER	A
3/4 COPPER	2 1/2 x 2 1/4	1	3 1/2
	2 1/2 x 2 3/4		
	3 3/4 x 2 3/4	2	4 3/16
1" COPPER	2 1/2 x 2 3/4	1	3 5/8
	3 3/4 x 2 3/4	2	4 5/16
	5" x 2 3/4	3A	4 3/4
1 1/4 COPPER	3 3/4 x 2 3/4	2	4 1/2
	5" x 2 3/4	3A	4 7/8
1" STEEL	3 3/4 x 2 3/4	2	4 7/16
	5" x 2 3/4	3A	4 7/8
1 1/4 STEEL	3 3/4 x 2 3/4	2	4 11/16
	5" x 2 3/4	3A	5 1/16

# FULL BACKPLATE INSTALLATION

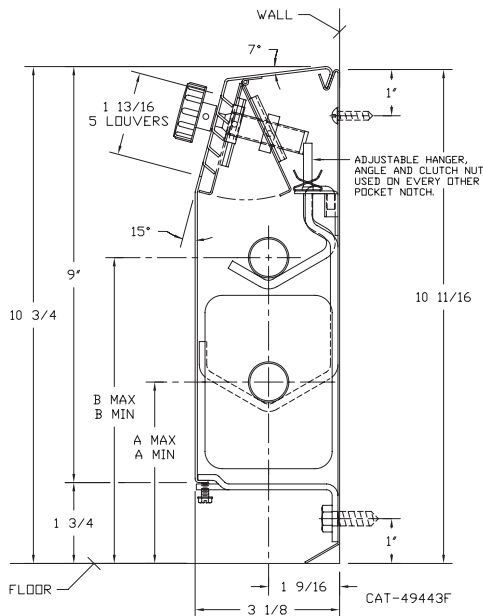

TUBE SIZE	FIN SIZE HEIGHT x WIDTH	A	B MIN	B MAX
3/4 COPPER	3 3/4 x 2 3/4	3 13/16	6 7/8	7 1/8
1" COPPER	3 3/4 x 2 3/4	3 15/16		
1 1/4 COPPER	3 3/4 x 2 3/4	4 1/8	6 5/8	
1" STEEL	3 3/4 x 2 3/4	4 1/16		

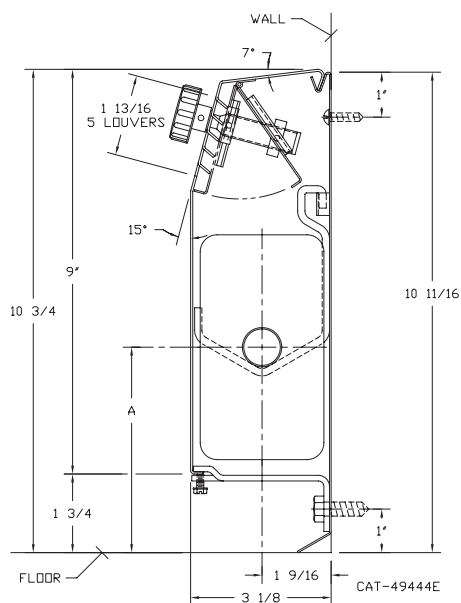

TUBE SIZE	FIN SIZE HEIGHT x WIDTH	A
1" COPPER	5" x 2 3/4	4 7/16
1 1/4 COPPER	5" x 2 3/4	4 9/16
1" STEEL	5" x 2 3/4	4 9/16
1 1/4 STEEL	5" x 2 3/4	4 3/4

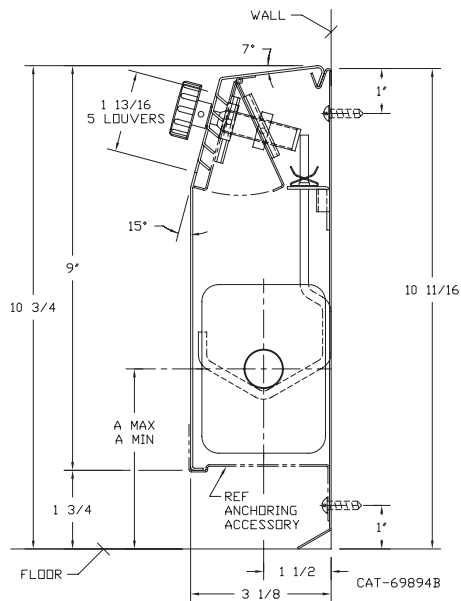

TUBE SIZE	FIN SIZE HEIGHT x WIDTH	A MIN	A MAX
3/4 COPPER	2 1/2 x 2 1/4	3 1/4	5 1/4
	2 1/2 x 2 3/4		
	3 3/4 x 2 3/4	3 7/8	5 3/8
1" COPPER	2 1/2 x 2 3/4	3 1/4	5 1/4
	3 3/4 x 2 3/4	3 7/8	5 3/8
	5" x 2 3/4	4 1/2	5 1/4
1 1/4 COPPER	3 3/4 x 2 3/4	3 7/8	5 3/8
	5" x 2 3/4	4 1/2	5 1/4
1" STEEL	3 3/4 x 2 3/4	3 7/8	5 3/8
	5" x 2 3/4	4 1/2	5 1/4
1 1/4 STEEL	3 3/4 x 2 3/4	3 7/8	5 3/8
	5" x 2 3/4	4 1/2	5 1/4

# PARTIAL BACKPLATE INSTALLATION

## Rod Hanger Installation

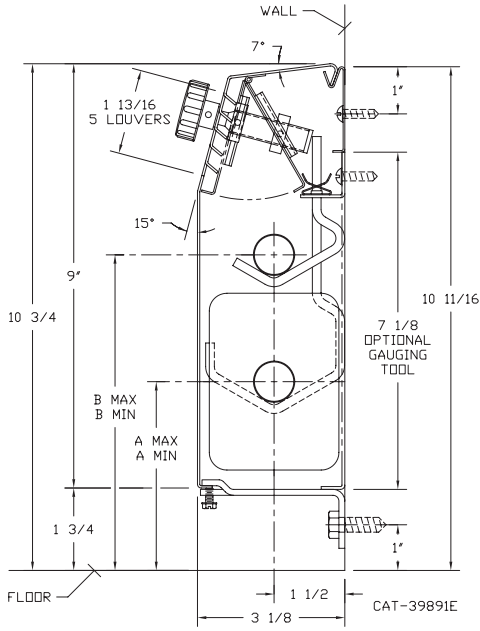

TUBE SIZE	FIN SIZE HEIGHT x WIDTH	A MIN	A MAX	B MIN	B MAX
3/4 COPPER	2 1/2 x 2 1/4	3 1/4	5 1/4	6 1/8	7 1/8
	2 1/2 x 2 3/4				
1" COPPER	3 3/4 x 2 3/4	3 7/8	5 3/8	6 5/8	7 1/8
	2 1/2 x 2 3/4	3 1/4	5 1/4	6 1/8	7 1/8
	5" x 2 3/4	4 1/2	5 1/4	N/A	N/A
1 1/4 COPPER	3 3/4 x 2 3/4	3 7/8	5 3/8	6 5/8	7 1/8
	5" x 2 3/4	4 1/2	5 1/4	N/A	N/A
1" STEEL	3 3/4 x 2 3/4	3 7/8	5 3/8	6 5/8	7 1/8
	5" x 2 3/4	4 1/2	5 1/4	N/A	N/A
1 1/4 STEEL	3 3/4 x 2 3/4	3 7/8	5 3/8	6 5/8	7 1/8
	5" x 2 3/4	4 1/2	5 1/4	N/A	N/A

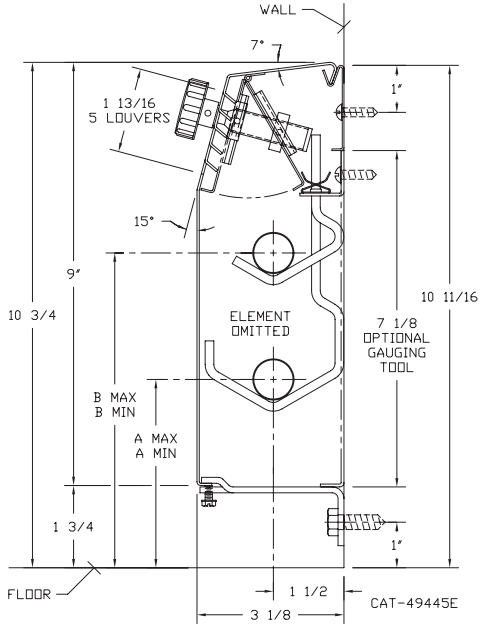

TUBE SIZE	FIN SIZE HEIGHT x WIDTH	A MIN	A MAX	B MIN	B MAX
3/4 COPPER	2 1/2 x 2 1/4	3 1/4	5 1/4	6 1/8	7 1/8
	2 1/2 x 2 3/4				
1" COPPER	3 3/4 x 2 3/4	3 7/8	5 3/8	6 5/8	7 1/8
	2 1/2 x 2 3/4	3 1/4	5 1/4	6 1/8	7 1/8
	5" x 2 3/4	4 1/2	5 1/4	N/A	N/A
1 1/4 COPPER	3 3/4 x 2 3/4	3 7/8	5 3/8	6 5/8	7 1/8
	5" x 2 3/4	4 1/2	5 1/4	N/A	N/A
1" STEEL	3 3/4 x 2 3/4	3 7/8	5 3/8	6 5/8	7 1/8
	5" x 2 3/4	4 1/2	5 1/4	N/A	N/A
1 1/4 STEEL	3 3/4 x 2 3/4	3 7/8	5 3/8	6 5/8	7 1/8
	5" x 2 3/4	4 1/2	5 1/4	N/A	N/A

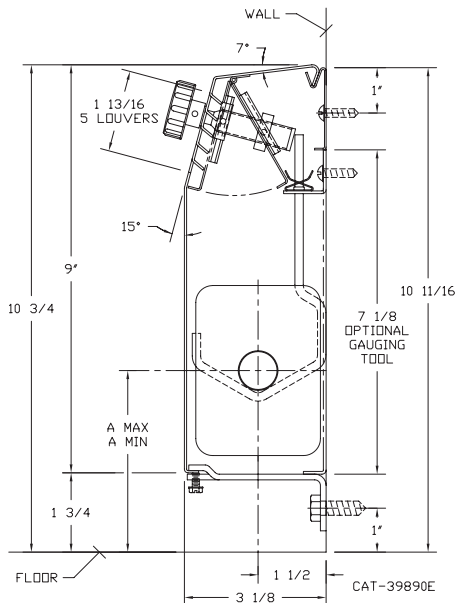

TUBE SIZE	FIN SIZE HEIGHT x WIDTH	A MIN	A MAX
3/4 COPPER	2 1/2 x 2 1/4	3 1/4	5 1/4
	2 1/2 x 2 3/4		
1" COPPER	3 3/4 x 2 3/4	3 7/8	5 3/8
	2 1/2 x 2 3/4	3 1/4	5 1/4
	5" x 2 3/4	4 1/2	5 1/4
1 1/4 COPPER	3 3/4 x 2 3/4	3 7/8	5 3/8
1" STEEL	3 3/4 x 2 3/4	3 7/8	5 3/8
	5" x 2 3/4	4 1/2	5 1/4
1 1/4 STEEL	3 3/4 x 2 3/4	3 7/8	5 3/8
	5" x 2 3/4	4 1/2	5 1/4

**STYLE Light Commercial "LB-2"**

**COPPER/ALUMINUM ELEMENT RATINGS**

ALL RATINGS ARE BASED ON 65° EAT

TUBE SIZE	CATALOG DESIGNATION	FIN SIZE HEIGHT X WIDTH	FINS PER FT.	FIN THICKNESS IN INCHES	WATER RATE IN G.P.M.	HOT WATER (AVG.)									
						215°	200°	190°	180°	170°	160°	150°	140°	130°	120°
3/4"	R02	2-1/2" x 2-3/4"	60	.010	1	1010	890	800	720	630	550	470	390	320	260
					4	1070	940	850	760	670	580	500	420	350	280
1"	R03	2-1/2" x 2-3/4"	55	.011	1	990	870	790	710	620	540	460	390	320	250
					4	1050	920	840	750	660	570	490	410	340	270
3/4"	R04	3-3/4" x 2-3/4"	50	.014	1	1070	950	850	770	680	590	510	430	350	280
					4	1130	1000	900	810	720	620	530	450	370	290
1"	R05	3-3/4" x 2-3/4"	50	.014	1	1080	960	860	780	690	600	520	440	360	290
					4	1140	1010	910	820	730	630	540	450	370	300
1"	R07	5" x 2-3/4"	50	.020	1	1060	930	840	740	650	560	470	390	320	260
					4	1120	980	890	780	680	590	500	420	350	280
1-1/4"	R08	3-3/4" x 2-3/4"	50	.02	1	1070	930	840	740	650	560	470	390	320	260
					4	1130	980	890	780	680	590	500	420	350	280
1-1/4"	R10	5" x 2-3/4"	50	.020	1	1080	940	840	750	660	560	470	390	320	260
					4	1140	990	890	790	690	590	500	420	350	280

**STYLE Light Commercial "LB-2"**

**STEEL ELEMENT RATINGS**

ALL RATINGS ARE BASED ON 65° EAT

TUBE SIZE	CATALOG DESIGNATION	FIN SIZE HEIGHT X WIDTH	FINS PER FT.	FIN THICKNESS IN INCHES	WATER RATE IN G.P.M.	HOT WATER (AVG.)									
						215°	200°	190°	180°	170°	160°	150°	140°	130°	120°
1"	R12	5" x 2-3/4"	50	.024	1	1000	880	800	720	630	550	470	390	320	260
					4	1060	930	850	760	670	580	500	420	350	280
1-1/4"	R13	5" x 2-3/4"	50	.024	1	1020	900	810	730	640	560	480	400	330	260
					4	1080	960	860	770	680	590	510	430	350	280